

RoHS

REV.	LOCAS.	DESCRIPTION	DRAW.	DATE.
01	New	INITIAL RELEASE.	Junly	2013.05.13
02		DRAWING UPDATE.	Leo	2014.05.25
03		DRAWING UPDATE.	Leo	2014.07.15

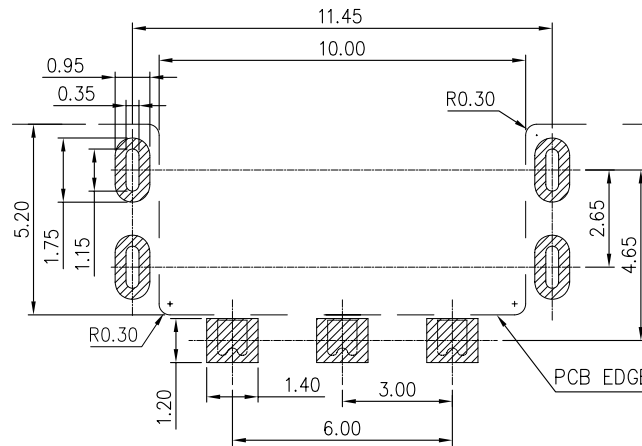
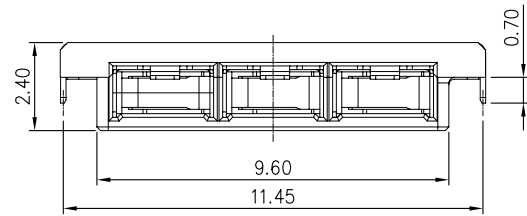
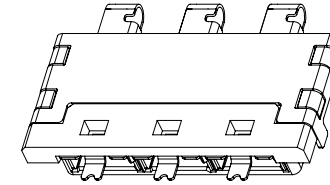
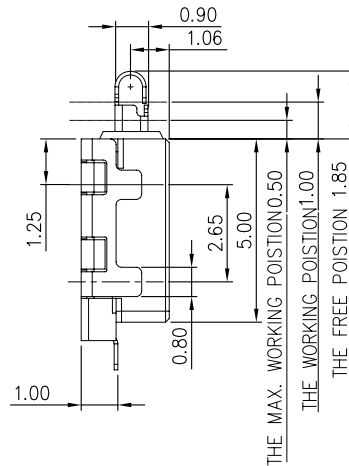
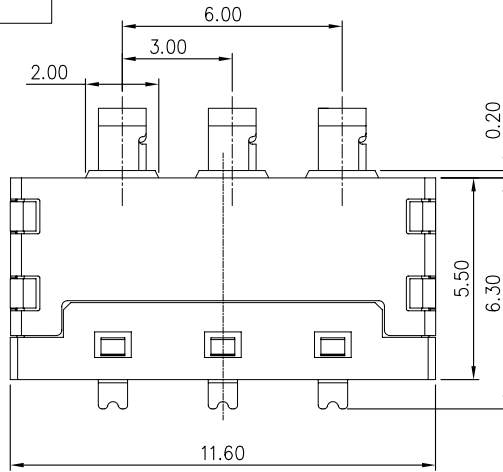

NOTES:

- MATERIAL:
  - HOUSING: THERMOPLASTIC,UL 94V-0, COLOR:BLACK
  - CONTACT: COPPER ALLOY T=0.10mm
  - SHELL: STAINLESS STEEL T=0.15mm
- SPECIALITY:
  - Rated current: 4.0A
  - Rated voltage: 250V
  - Contact Resistance: 50mΩ MAX
  - Insulation Resistance: 1000MΩ MIN 500V DC
  - Dielectric withstanding voltage: 500V DC.
  - Solder ability: 250±5°C, 10±0.5s.
  - Durability: 5000 Cycles Min.Contact Resistance 100mΩ Max
  - Operating condition: Temperature -40°C ~ +85°C; Humidity 80% R.H MAX
- PLEASE CONTACT JITS SALES REPRESENTATIVE TO VERIFY PRODUCT DETAILS & AVAILABILITY

RECOMMENDED PCB LAYOUT  
TOLERANCE(.XX±0.05)

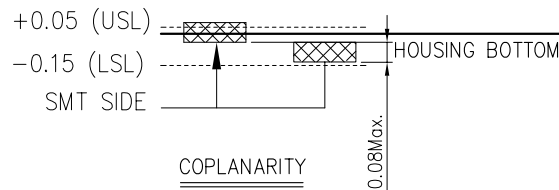
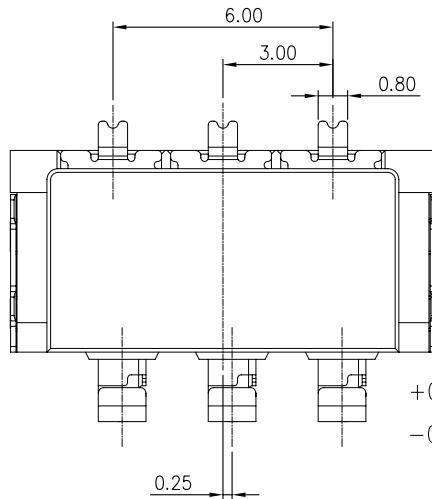

MEASURE POINT:  
QUADRANT POINT (QP)  
TANGENCY POINT (TP)  
INTERSECTION POINT (IP)

UNLESS OTHERWISE SPECIFIED, TOLERANCE:  
X. ±0.25  
X.X ±0.20  
X.XX ±0.15  
ANGULAR ±3°



DESING	Leo	DATE	2014.07.15	TITLE:					
CHECKED	Nick	DATE	2014.07.15	3PIN 3.00MM PITCH BATTERY H=2.40MM -D Type					
APPROVED	Talen	DATE	2014.07.15						
PART NO:	BA100-1A301D			REV:	03	SCALE:	1:1	UNIT:	mm
DRAWING NO:	BA100-1A301D			SIZE:	A4	SHEET:	1/2		

RoHS

User Direction of Unreeling

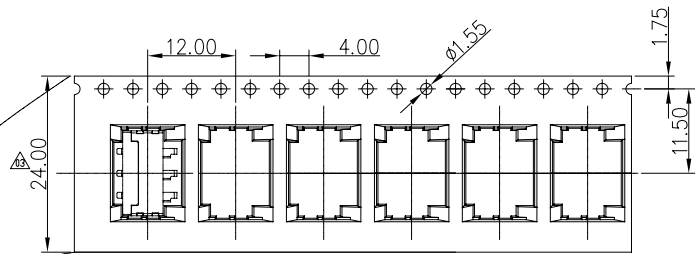

COVER TAPE PEELING ANGLE: 165°~180°  
PEELING FORCE: 20~130g

CARRIER TAPE

User Direction of Unreeling

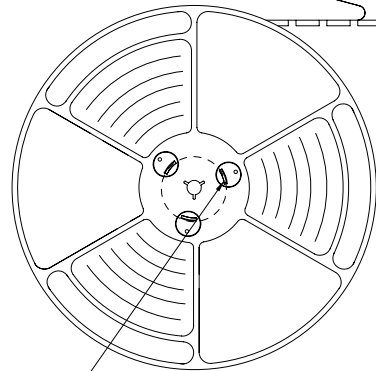

DETAIL B

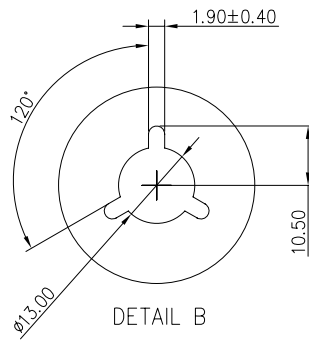

DETAIL B

NOTES

- 1. NUMBER OF CONNECTORS: 1800PCS/REEL
- 2. LEAD TAPE LENGTH

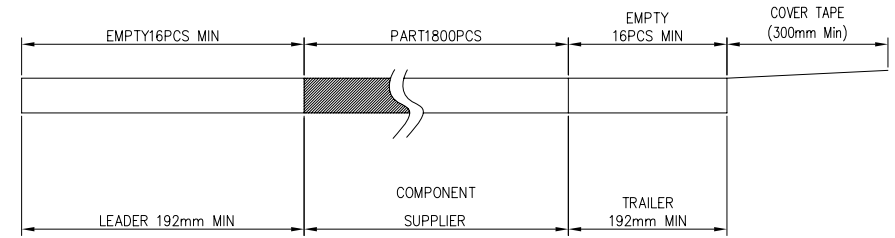

- 3. QUANTITY: 14400PCS/CARTON
- 4. WEIGHT :
  - 3.1 NET WEIGHT : 3.46Kg
  - 3.2 GROSS WEIGHT : 5.35Kg

CARTON  
342\*342\*250 K=K

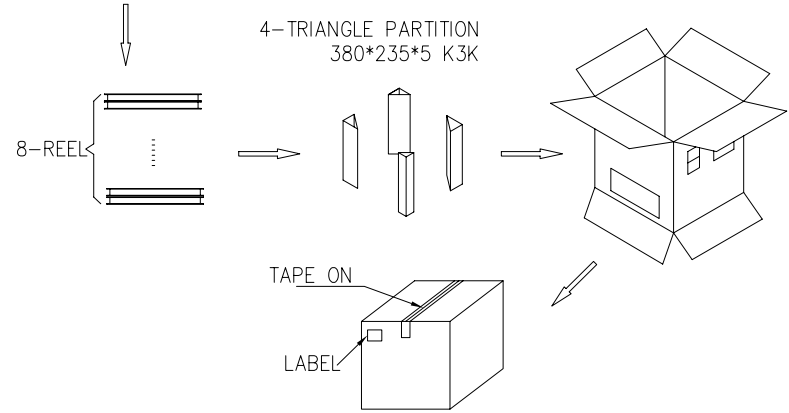

MEASURE POINT:  
 QUADRANT POINT (QP)  
 TANGENCY POINT (TP)  
 INTERSECTION POINT (IP)

UNLESS OTHERWISE SPECIFIED, TOLERANCE:  
 X. ±0.25  
 X.X ±0.20  
 X.XX ±0.15  
 ANGULAR ±3°



DESING	Leo	DATE	2014.07.15	TITLE:	3PIN 3.00MM PITCH BATTERY H=2.40MM -D Type				
CHECKED	Nick	DATE	2014.07.15						
APPROVED	Talen	DATE	2014.07.15						
PART NO:	BA100-1A301D			REV:	03	SCALE:	1:1	UNIT:	mm
DRAWING NO:	BA100-1A301D			SIZE:	A4	SHEET:	2/2		