

RoHS HF

REV.	LOCAS.	DESCRIPTION	DRAW	DATE.
A	NEW	INITIAL RELEASE.	Junly	20160204
B	MODIFY	Add HF	TEDDY	20160523
C	MODIFY	Change plating spce	TEDDY	20160526

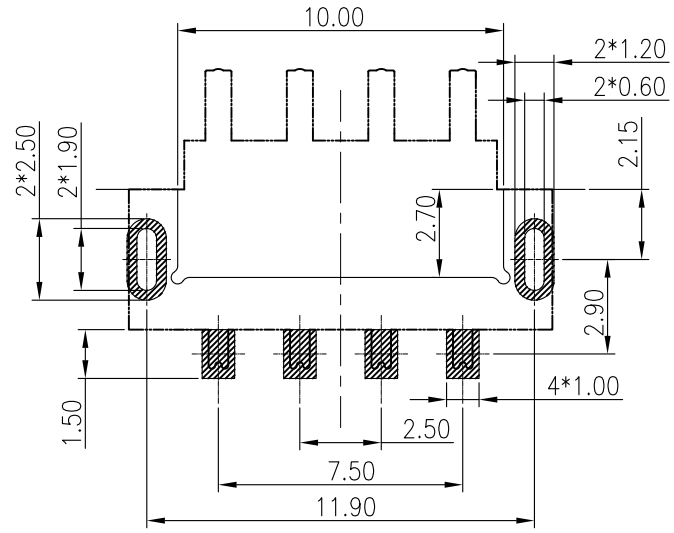

RECOMMENDED PCB LAYOUT
TOLERANCE(.XX±0.05)

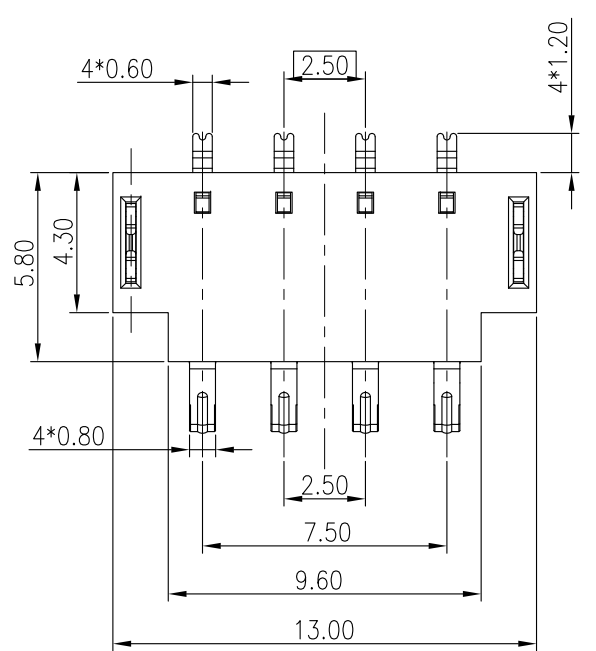
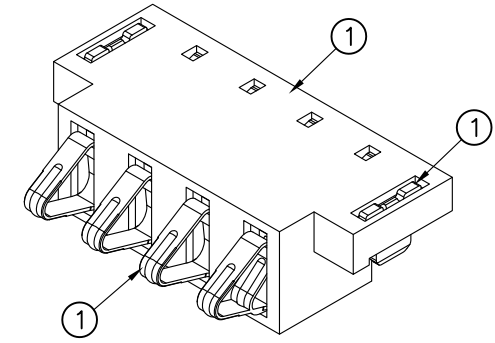
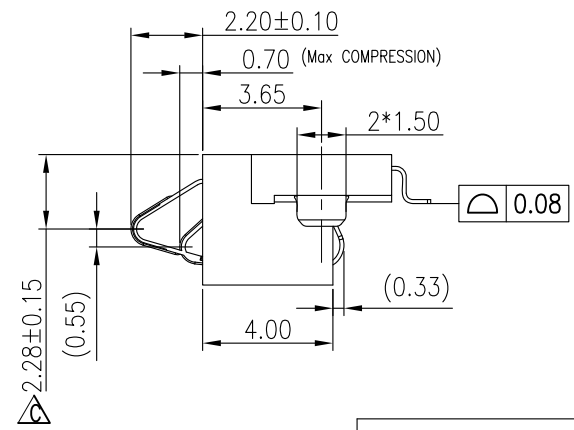
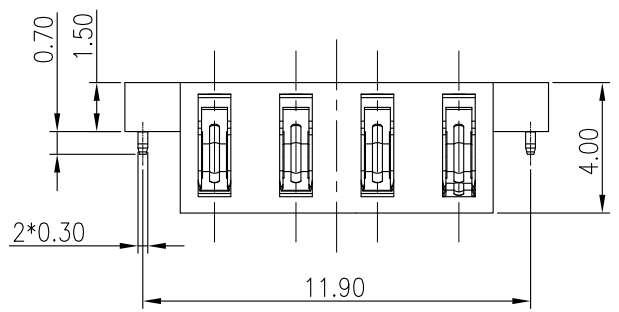

NOTES:

- MATERIAL:
 - 1.1 Housing:High Temperature Thermoplastic LCP+40%GF G930 UL94V-0; Color Black.
 - 1.2 Terminal:Copper Alloy
 - 1.3 LATCH:Stainless Steel
- PLATING:
 - 2.1 Terminal:60u" Min.Ni Plating over all. Au Plated over mating area see table.
 - 2.2 LATCH:30u" Min.Ni Plating over all. 100u" Min Matte Sn Plated over all.
- SPECIALITY:
 - 3.1 Rated current:2.0A
 - 3.2 Rated voltage:30V
 - 3.3 Contact Resistance:50Ω
 - 3.4 Insulation Resistance:1000MΩ
 - 3.5 Dielectric withstanding voltage: 500V AC.
 - 3.6 Solder ability:255±5°,5±0.5s.
 - 3.7 Durability:5000 Cycles Min.
 - 3.8 Operating condition:Temperature: -40°+85° Humidity: 80% R.H Max

TABLE:

NO	Description	Dosage	Material	Color/plating
3	Housing	1PC	LCP UL94V-0	BLACK
2	Latch	2PC	SUS304-1/2H T=0.30	Plating Sn : 100u",Ni: 30u"Min
1	Termiral	4PC	YCUT-FX-EH,T=0.12mm	Contact au: 5u";Ni:60u"Min;Slider Tails:1u"Au

MEASURE POINT: QP
 QUADRANT POINT TP
 TANGERCY POINT IP
 INTERSECTION POINT

UNLESS OTHERWISE SPECIFIED, TOLERANCE:
 X. iA0.25
 X.X iA0.20
 X.XX iA0.15
 ANGULAR iA3iθ



DESING	Fei	DATE	2016.05.04	TITLE:	4PIN 2.5 Battery H=4.0mm		
CHECKED	Nick	DATE	2016.05.04				
APPROVED	Haiyon	DATE	2016.05.04				
PART NO: BA150-R0405A			REV: C	SCALE: 1:1	UNIT: mm		
DRAWING NO: BA150-R0405A			SIZE: A4	SHEET: 1/2			

RoHS HF

User Direction of Unreeling

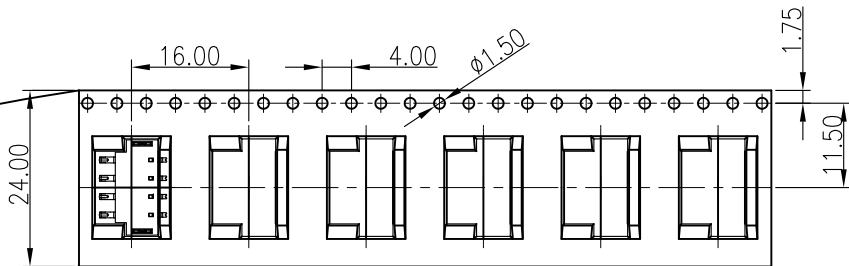

COVER TAPE PEELING ANGLE: 165°~180°
PEELING FORCE: 20~130g

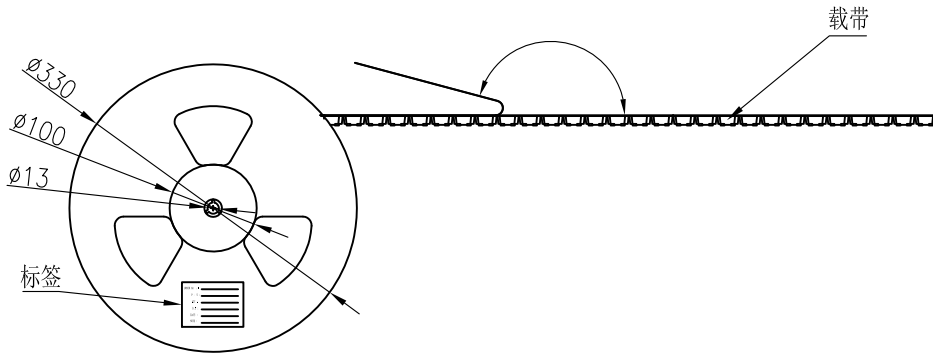

NOTES

1. NUMBER OF CONNECT ORS: 1000 PCS/REEL
2. LEAD TAPE LENGTH

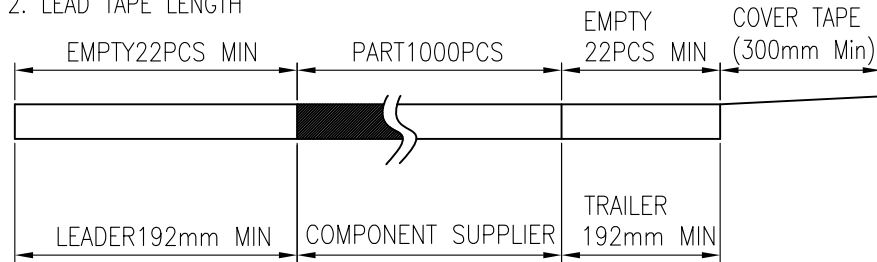

3. QUANTITY: 8000 PCS/CARTON
4. WEIGHT :
 - 4.1 NET WEIGHT : 3.46 Kg
 - 4.2 GROSS WEIGHT : 5.35 Kg

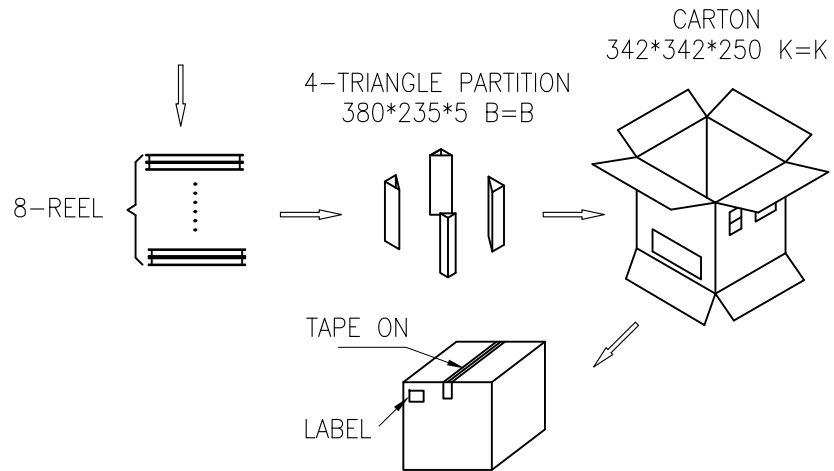

MEASURE POINT:
QUADRANT POINT (QP)
TANGENCY POINT (TP)
INTERSECTION POINT (IP)

JTS JITS
TECHNOLOGY CO., LIMITED

UNLESS OTHERWISE SPECIFIED, TOLERANCE:
X. iA0.25
X.x iA0.20
X.xx iA0.15
ANGULAR iA3iδ

DESING	Fei	DATE	2016.05.04	TITLE:				
CHECKED	Nick	DATE	2016.05.04		4PIN 2.5 Battery H=4.0mm			
APPROVED	Haiyon	DATE	2016.05.04					
PART NO:	BA150-R0405A		REV:	C	SCALE:	1:1	UNIT:	mm
DRAWING NO:	BA150-R0405A		SIZE:	A4	SHEET:	2/2		