

RoHS

REV.	LOCAS.	DESCRIPTION	DRAW.	DATE.
1	△ X1	Add a description in the Note	Gong	2014.12.09
2		Update Drawing	Liman.li	2016.01.22

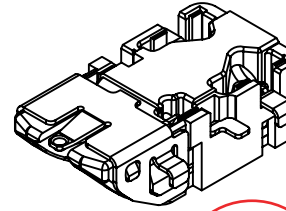
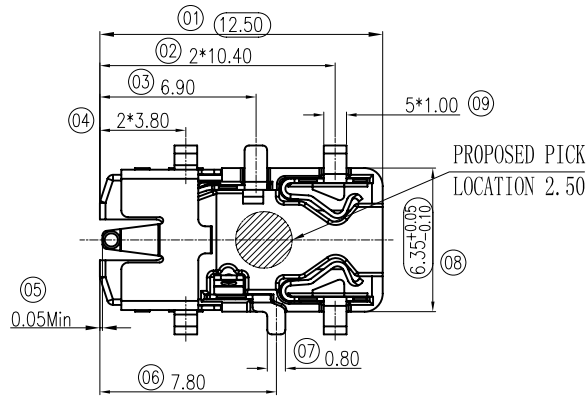

受控文件
 2016.03.23
 文控中心

NOTES:

- MATERIAL:SEE TABLE (Can't add recycled material)
- SPECIALITY:
 - Rated current:DC12V 1.0A
 - Rated voltage:30V
 - Contact Resistance:50mΩ MAX
 - Insulation Resistance:1000MΩ MIN 500V DC
 - Dielectric withstanding voltage: 500V AC 1Min.
 - Solder ability:245±5°C, 5±0.5s.
 - Durability:5000 Cycles Min.
 - Operating condition:Temperature-30°C~+80°C; Humidity 80% R.H MAX

3. MECHANICAL:

- Insertion Force:20N MAX.
- Extraction Force:7N MIN Initial, 5N MIN After Test.

4. PLEASE CONTACT JITS SALES REPRESENTATIVE TO VERIFY PRODUCT DETAILS & AVAILABILITY

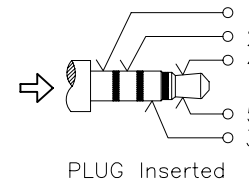
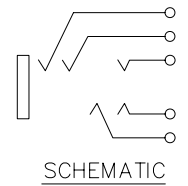
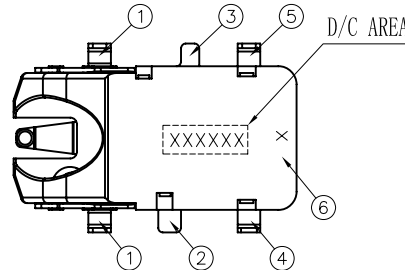
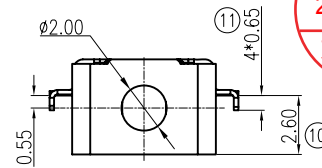
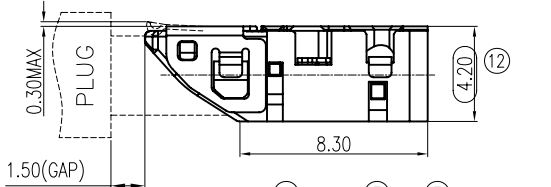
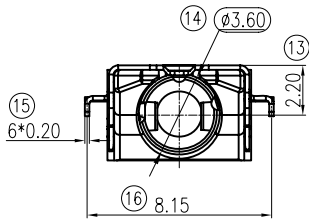

D/C AREA DESCRIBE:

XXXXXX
 Line:A=A Line,B=B Line
 Day/night shift:A=Day shift,B=Night shift
 Day:1=MON,2=TUE
 Weeks:01=one weeks ...
 Years:4=2014

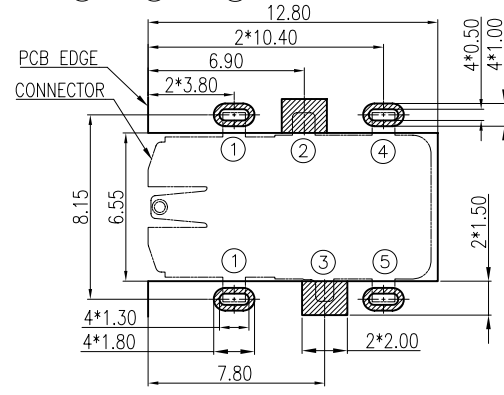
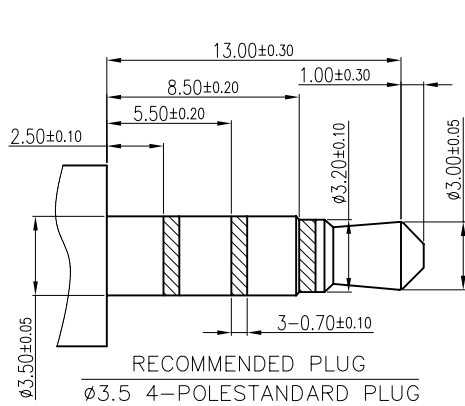

Symbol	Meaning
⊗	CTQ
⊗	CPK

MEASURE POINT: (QP)
 QUADRANT POINT (QP)
 TANGENCY POINT (TP)
 INTERSECTION POINT (IP)

UNLESS OTHERWISE SPECIFIED, TOLERANCE:
 X. iA0.25
 X.x iA0.20
 X.xx iA0.15
 ANGULAR iA3i8

6	Housing	1PC	PA10T	BLACK
5	Terminal 5	1PC	C5210-EH,T=0.20	Contact Au:5u",solder Au:2u",Ni:60u"min
4	Terminal 4	1PC	C5210-EH,T=0.20	Contact Au:5u",solder Au:2u",Ni:60u"min
3	Terminal 3	1PC	C5210-EH,T=0.20	Contact Au:5u",solder Au:2u",Ni:60u"min
2	Terminal 2	1PC	C5210-EH,T=0.20	Contact Au:5u",solder Au:2u",Ni:60u"min
1	Terminal 1	1PC	C5210-EH,T=0.20	Contact Au:5u",solder Au:2u",Ni:60u"min
NO	Description	Dosage	Material	Color/solder

JITS JITS TECHNOLOGY CO., LIMITED

DESING	DATE	TITLE:	REV:	SCALE:	UNIT:
CHECKED	DATE	xqc;ø3.5 PHONE JACK 4.2H, 5P,STD,REVERSESUBSIDE2.6	2	1:1	mm
APPROVED	DATE				
PART NO: DA420-V510A		REV: 2	SCALE: 1:1	UNIT: mm	
DRAWING NO: DA420-V510A		SIZE: A4	SHEET: 1/2		

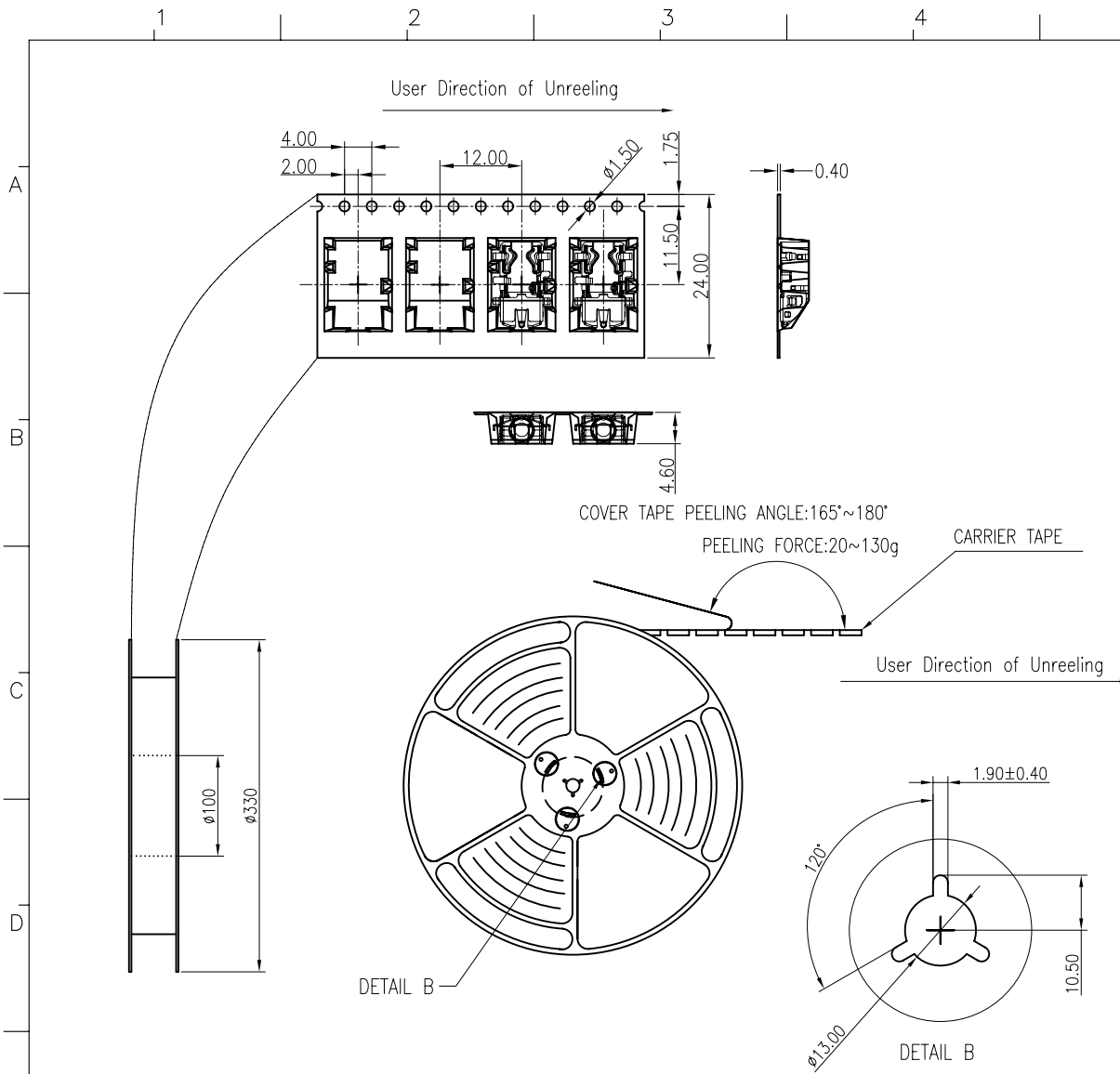

NOTES

1. NUMBER OF CONNECTORS:1000PCS/REEL
2. LEAD TAPE LENGTH

EMPTY 20PCS MIN	PART 1000PCS	EMPTY 20PCS MIN	COVER TAPE (300mm Min)
LEADER 240mm MIN		TRAILER 240mm MIN	
COMPONENT SUPPLIER		TRAILER	
3. QUANTITY:8000PCS/CARTON
4. WEIGHT :
 - 3.1 NET WEIGHT : 2.64Kg
 - 3.2 GROSS WEIGHT : 5.43Kg

受控文件
 2016.03.23
 文控中心

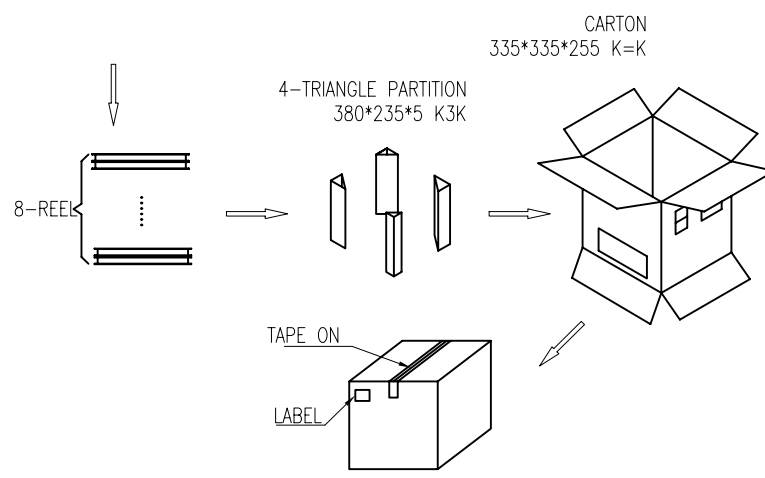

MEASURE POINT: QUADRANT POINT (QP) TANGENCY POINT (TP) INTERSECTION POINT (IP)	JTS		JTS TECHNOLOGY CO., LIMITED	
UNLESS OTHERWISE SPECIFIED, TOLERANCE: X. iA0.25 X.x iA0.20 X.xx iA0.15 ANGULAR iA3i8	DESING Liman.li DATE 2016.01.22 CHECKED Peter DATE 2016.01.22 APPROVED Haiyong.Luo DATE 2016.01.22	TITLE: Ø3.5 PHONE JACK 4.2H, 5P, STD, REVERSESUBSIDE2.6		
PART NO: DA420-V510A DRAWING NO: DA420-V510A	REV: 2 SCALE: 1:1 UNIT: mm	SIZE: A4 SHEET: 2/2		