

RoHS

REV.	LOCAS.	DESCRIPTION	DRAW.	DATE.
01	NEW	INITIAL RELEASE.	Alan	2015.09.17

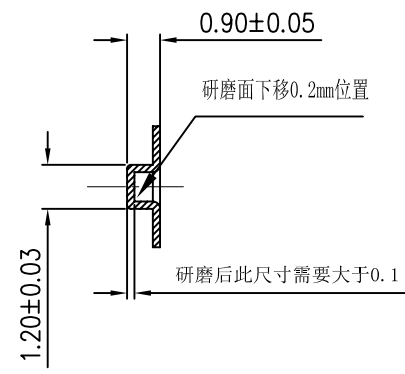
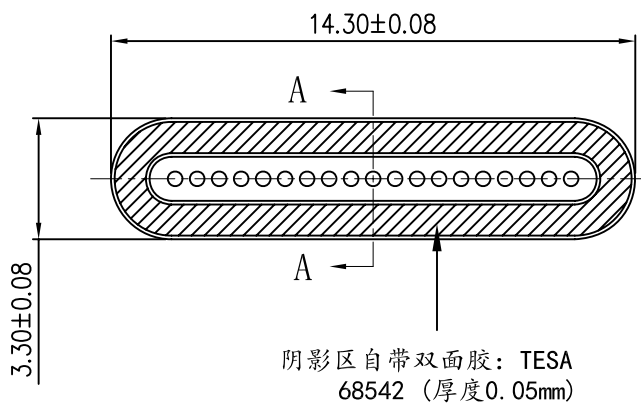
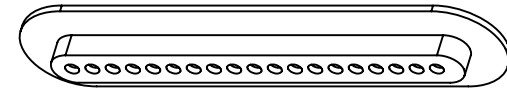
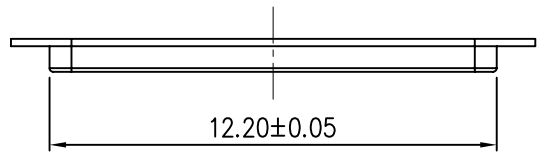

NOTES:

MATERIAL: SUS304 $\frac{1}{4}$ H. T=0.20mm;
 Minimum-Value Aperture: ϕ 0.40mm
 Pitch-Row: 0.60mm; Hole Count: 19 Pcs;

MEASURE POINT: QUADRANT POINT (QP) TANGENCY POINT (TP) INTERSECTION POINT (IP)				
	UNLESS OTHERWISE SPECIFIED, TOLERANCE: X. ±0.25 X.x ±0.20 X.xx ±0.15 ANGULAR ±3°	DESING Alan DATE 2015.09.17 CHECKED Peter DATE 2015.09.17 APPROVED Peter DATE 2015.09.17	TITLE: DUST HELMET T=0.20*14.30*3.30 H=*0.90mm	PART NO: EAJN-1510 DRAWING NO: EAJN-1510

RoHS

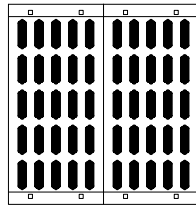

DUST HELMET

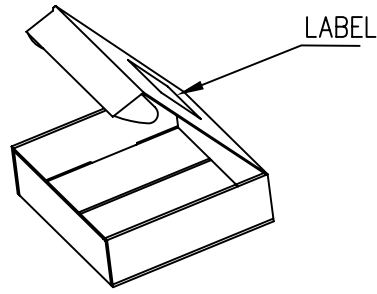

BOX

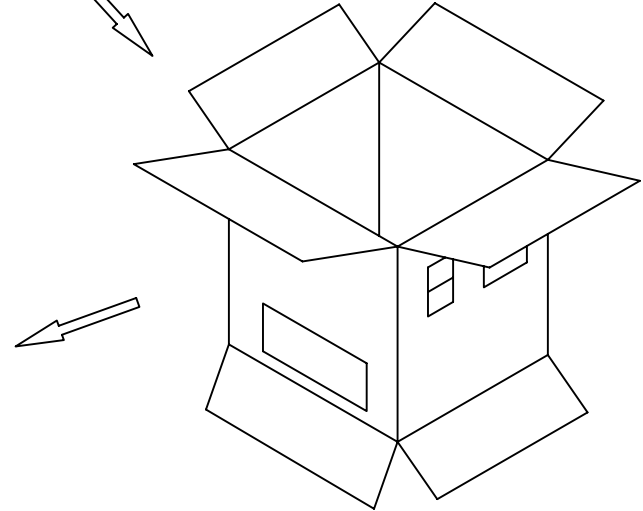

BOX

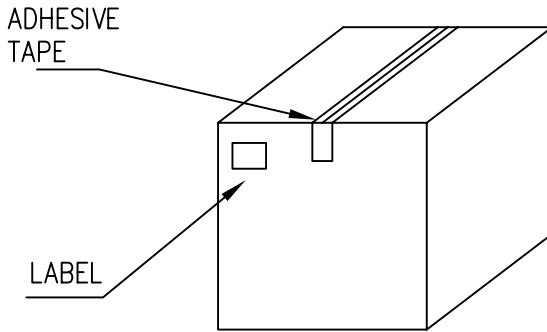

TABLE

	SPEC	QTY
SMALL PACKING	BOX 100*220*55 K3K	50000 PCS
LARGE PACKING	BOX 342*402*320 K=K	100000 PCS

MEASURE POINT:
 QUADRANT POINT (QP)
 TANGENCY POINT (TP)
 INTERSECTION POINT (IP)

UNLESS OTHERWISE SPECIFIED, TOLERANCE:
 X. ±0.25
 X.x ±0.20
 X.xx ±0.15
 ANGULAR ±3'



DESING	Alan	DATE	2015.09.17	TITLE:	DUST HELMET T=0.20*14.30*3.30 H=*0.90mm				
CHECKED	Peter	DATE	2015.09.17						
APPROVED	Peter	DATE	2015.09.17						
PART NO:	EAJN-1510			REV:	01	SCALE:	1:1	UNIT:	mm
DRAWING NO:	EAJN-1510			SIZE:	A4	SHEET:	2/2		