

RoHS

REV.	LOCAS.	DESCRIPTION	DRAW.	DATE.
A	NEW	INITIAL RELEASE.	May	2014.05.28
B	NEW	CHANGE THE PACKAGE	Andy	2014.06.27

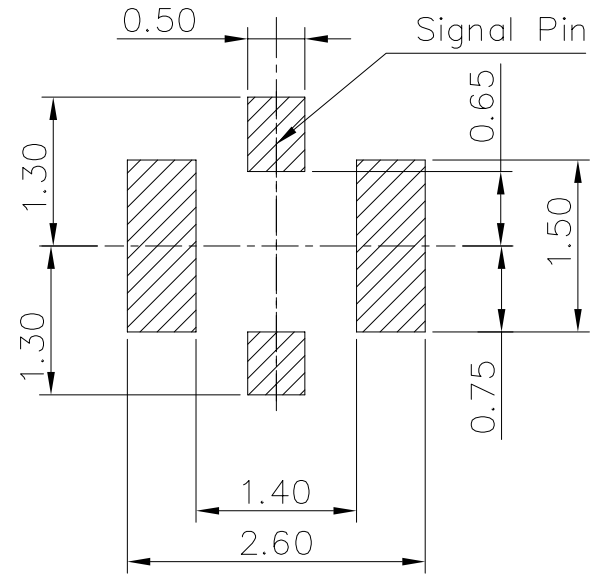
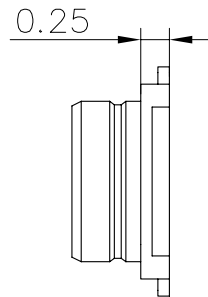
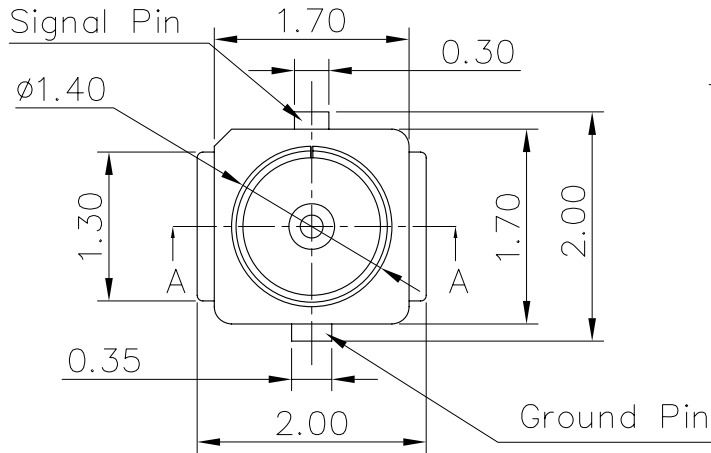
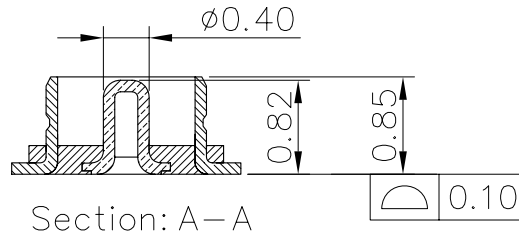
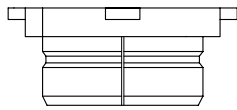

NOTES:

1. MATERIAL:

1.1 Housing: High Temperature Thermoplastic  
UL94V-0; Color Black.

1.2 Terminal: Copper Alloy.

1.3 Shell: Copper Alloy.

2. SPECIALITY:

2.1 Rated current: 1.0A

2.2 Rated voltage: 60V

2.3 Contact Resistance:

Signal Contact: 20 mohms Max;

Ground Contact: 20 mohms Max;

2.4 Insulation Resistance: 500Mohms MIN 100V DC

2.5 Dielectric withstanding voltage: 200V AC For 1minute.

2.6 Frequency rating: 0~6G Hz.

2.7 VSWR: 1.3 Max, 0~3GHz; 1.4 max. 3~6GHz.

2.8 Impedance: 50 ohms;

2.9 Solderability: 255°C±5°C; 5±0.5sec.

2.10 Durability: 30 Cycles.

2.11 Operating condition: Temperature -30°C~+80°C;

Humidity 80% R.H MAX

3. PLEASE CONTACT JITS SALES REPRESENTATIVE  
TO VERIFY PRODUCT DETAILS & AVAILABILITY

4. PART NO: R3BJ-L3B07.

RECOMMENDED PCB LAYOUT  
(PCB THICKNESS TOLERANCE: ±0.05)

MEASURE POINT:  
QUADRANT POINT (QP)  
TANGENCY POINT (TP)  
INTERSECTION POINT (IP)

**JITS** JITS  
TECHNOLOGY CO., LIMITED

UNLESS OTHERWISE  
SPECIFIED, TOLERANCE:  
X. ±0.25  
X.x ±0.20  
X.xx ±0.15  
ANGULAR ±3°

DESING	Andy	DATE	2014.05.28
CHECKED	Nick	DATE	2014.05.28
APPROVED	Jack	DATE	2014.05.28

TITLE:	RF III RECEPTACLE H=0.85mm, 4PADS		
PART NO:	R3BJ-L3B07	REV:	B
SCALE:	1:1	UNIT:	mm

DRAWING NO:	R3BJ-L3B07	SIZE:	A4	SHEET:	1/2		
-------------	------------	-------	----	--------	-----	--	--

RoHS

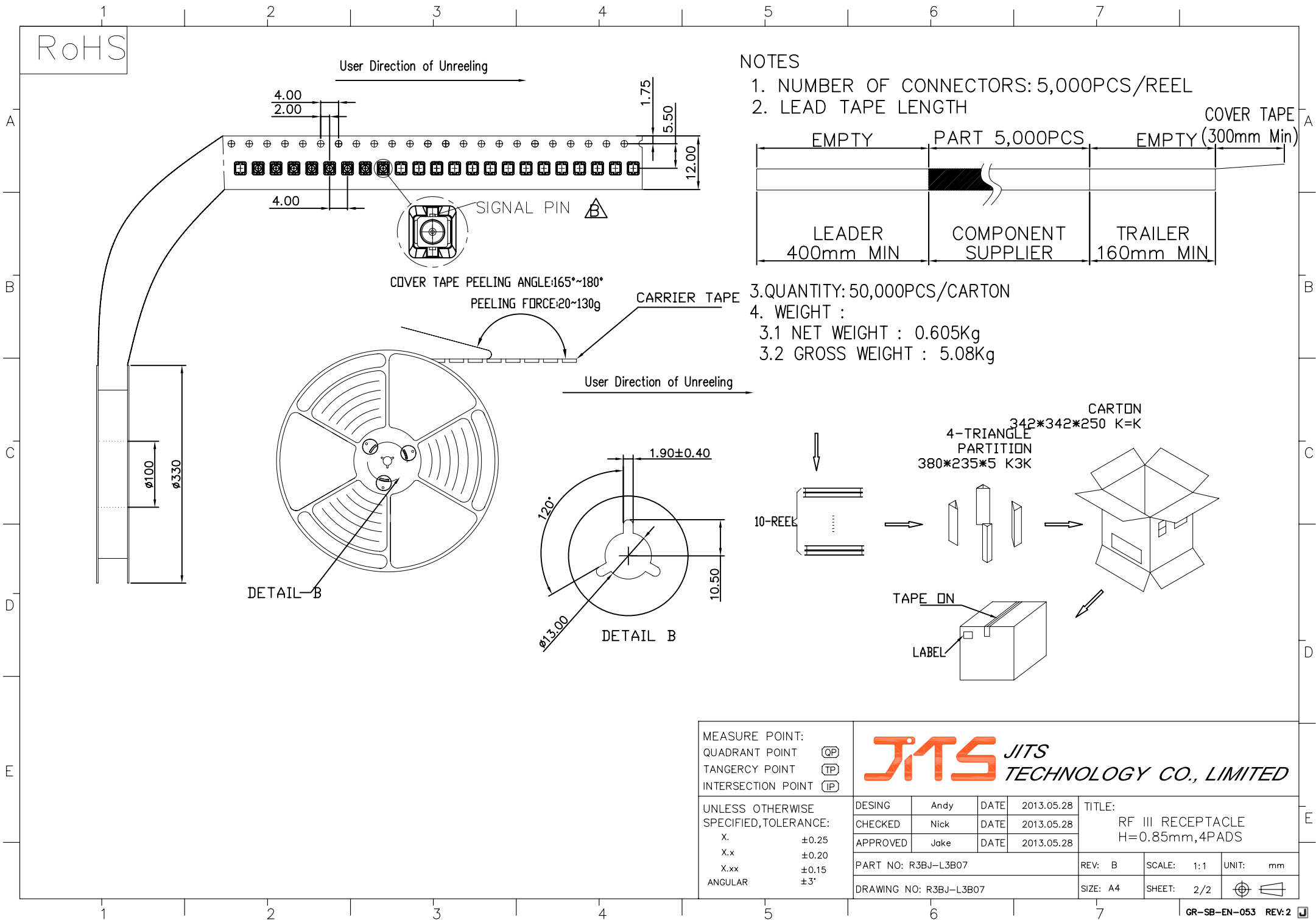

NOTES

1. NUMBER OF CONNECTORS: 5,000PCS/REEL
2. LEAD TAPE LENGTH
3. QUANTITY: 50,000PCS/CARTON
4. WEIGHT :
  - 3.1 NET WEIGHT : 0.605Kg
  - 3.2 GROSS WEIGHT : 5.08Kg

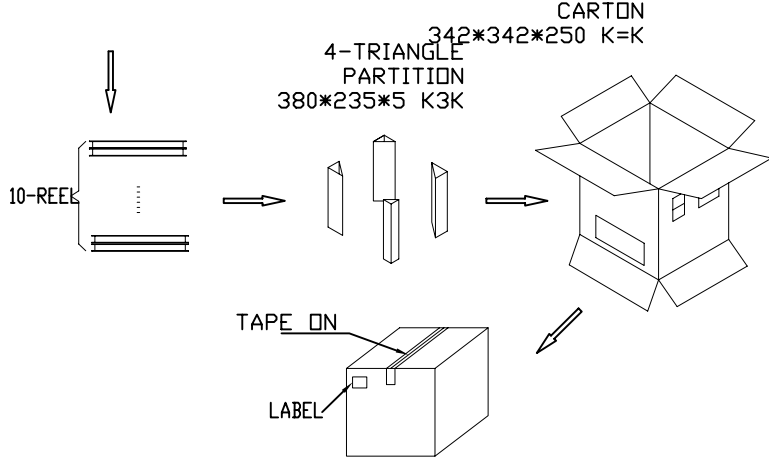
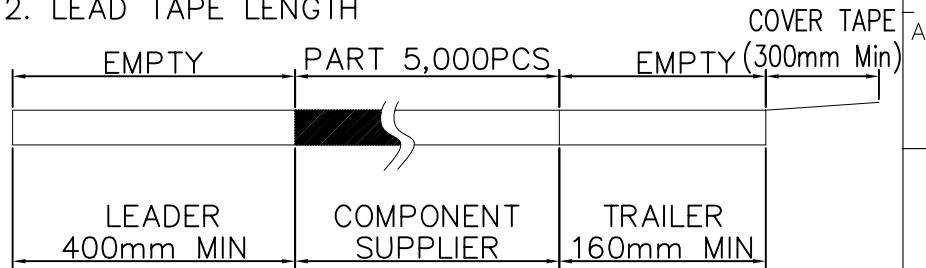

MEASURE POINT: QUADRANT POINT (QP) TANGENCY POINT (TP) INTERSECTION POINT (IP)				
	UNLESS OTHERWISE SPECIFIED, TOLERANCE: X. ±0.25 X.x ±0.20 X.xx ±0.15 ANGULAR ±3°	DESING Andy DATE 2013.05.28 CHECKED Nick DATE 2013.05.28 APPROVED Jake DATE 2013.05.28	TITLE: RF III RECEPTACLE H=0.85mm, 4PADS	REV: B SCALE: 1:1 UNIT: mm
PART NO: R3BJ-L3B07 DRAWING NO: R3BJ-L3B07	REV: B SIZE: A4	UNIT: mm	SHEET: 2/2	SHEET: 2/2