

| REV. | LOCAS. | DESCRIPTION | DRAW. | DATE. |
|------|--------|--------------------------|-------|------------|
| 02 | MODIFY | ECN-20150018 | Junly | 2012.04.21 |
| 03 | MODIFY | ECN-1408016 | Andy | 2014.08.11 |
| 04 | MODIFY | UPDATE THE DRAWING FRAME | Alan | 2016.03.16 |

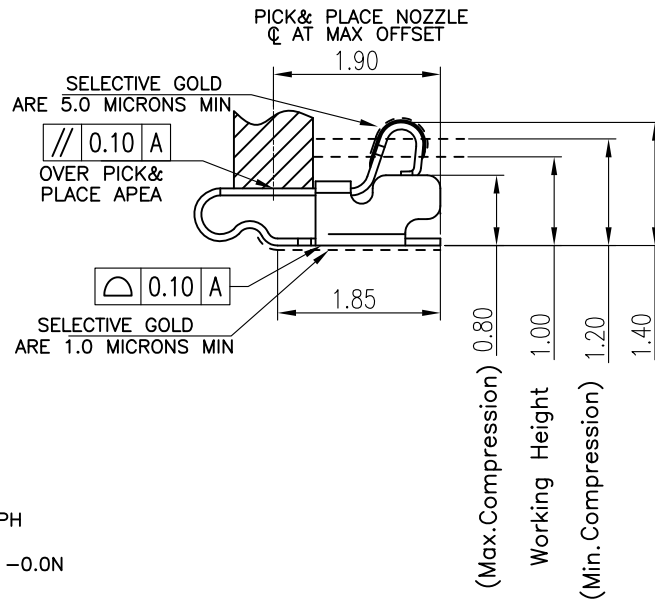

NOTES:

- MATERIAL:
 - Copper Alloy T=0.08mm
- SPECIALITY:
 - Contact Resistance: 30mΩ Max
 - Operating Temperature: -20°C~+65°C
 - Max. Beam Deflection: 0.5mm. On Contact POINT
- RF PERFORMANCE:
 - Impedance: 50 ohm.
 - Insertion Loss: 0.6dBMax.(DC~3GHz)
 - VSWR: 1.5MAX.(DC~3GHz)

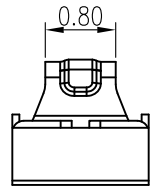
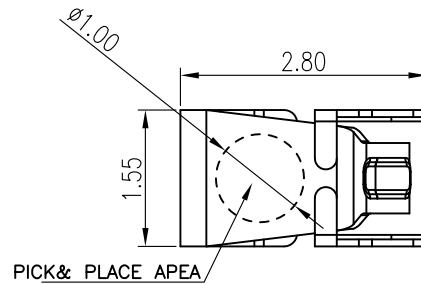
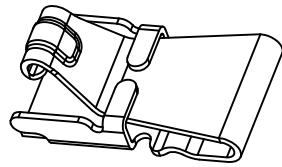
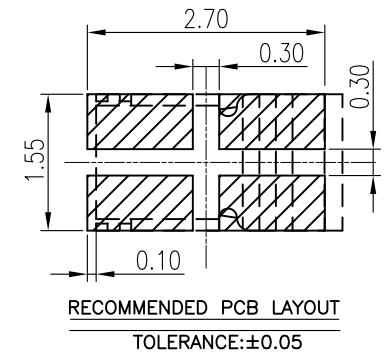
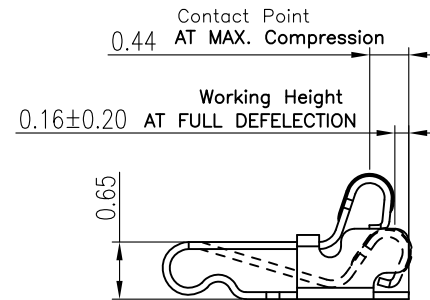

LOAD/DEFLECTION GRAPH
MINIMUM FORCE
TOLERANCE +0.25N / -0.0N

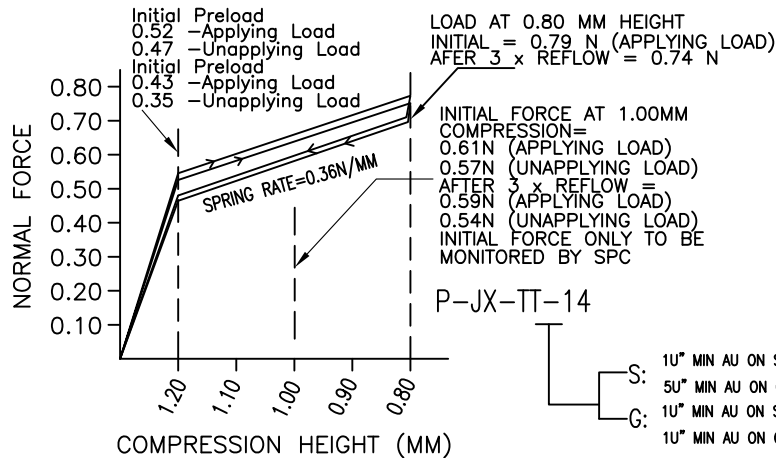

- S: 1U" MIN AU ON SOLDERING AREA
- 5U" MIN AU ON CONTACT AREA
- G: 1U" MIN AU ON SOLDERING AREA
- 1U" MIN AU ON CONTACT AREA

MEASURE POINT:
QUADRANT POINT (QP)
TANGENCY POINT (TP)
INTERSECTION POINT (IP)

JTS JITS
TECHNOLOGY CO., LIMITED

UNLESS OTHERWISE SPECIFIED, TOLERANCE:
X. ±0.25
X.x ±0.20
X.xx ±0.15
ANGULAR ±3°

| DESIGN | DATE | TITLE: |
|------------------------|------------|-----------------------------|
| CHECKED | 2016.03.16 | ANTENNA RF SPRING SMT TYPE |
| APPROVED | | H:1.40mm L:2.80*1.55*1.40mm |
| PART NO: P-JS-TT-14 | REV: 04 | SCALE: 16:1 UNIT: mm |
| DRAWING NO: P-JS-TT-14 | SIZE: A4 | SHEET: 1/2 |

RoHS

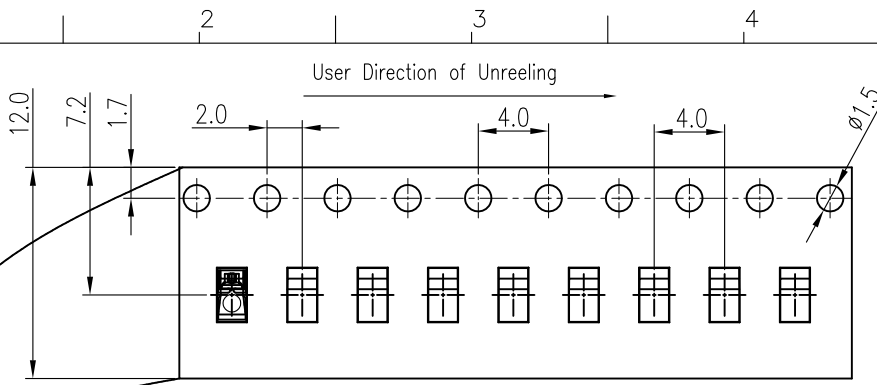

NOTES

- 1. NUMBER OF CONNECTORS:8000PCS/REEL
- 2. LEAD TAPE LENGTH

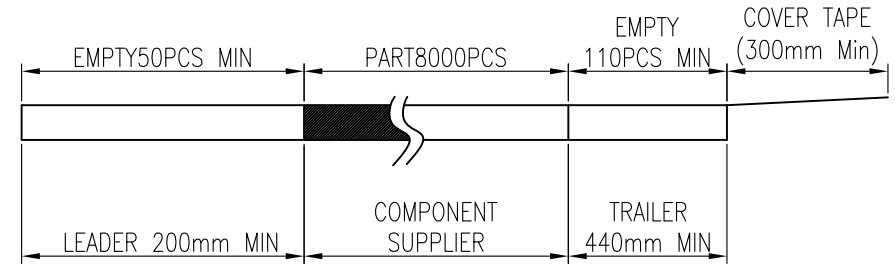

- 3. QUANTITY:96000PCS/CARTON
- 4. WEIGHT :
 - 3.1 NET WEIGHT : 2.88Kg
 - 3.2 GROSS WEIGHT : 6.28Kg

A

B

C

D

E

A

B

C

D

E

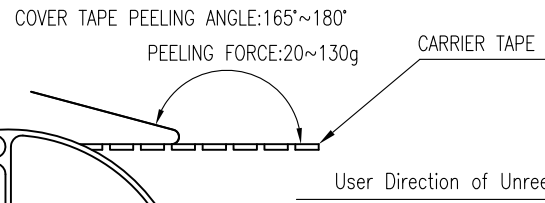

CARTON
342*342*250 K=K

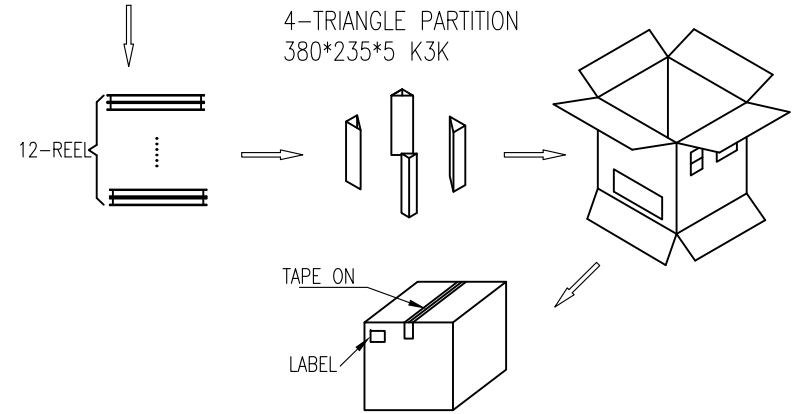
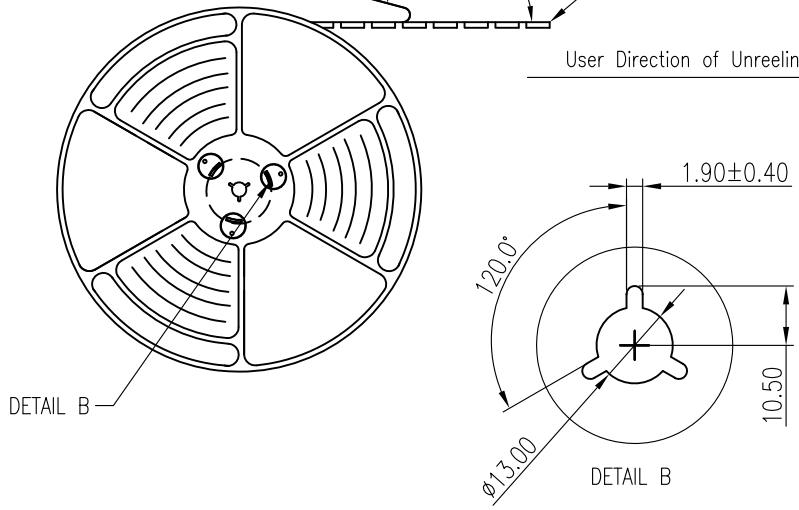

MEASURE POINT:
 QUADRANT POINT (QP)
 TANGENCY POINT (TP)
 INTERSECTION POINT (IP)

UNLESS OTHERWISE SPECIFIED, TOLERANCE:
 X ±0.25
 X.X ±0.20
 X.XX ±0.15
 ANGULAR ±3°



| | | | | |
|------------------------|------|---|------------|----------|
| DESIGN | DATE | TITLE: ANTENNA RF SPRING SMT TYPE H:1.40mm L:2.80*1.55*1.40mm | | |
| CHECKED | DATE | | | |
| APPROVED | DATE | | | |
| PART NO: P-JS-TT-14 | | REV: 04 | SCALE: 1:1 | UNIT: mm |
| DRAWING NO: P-JS-TT-14 | | SIZE: A4 | SHEET: 2/2 | |